

Trouble Shooting

PROBLEM	POSSIBLE CAUSE	WHAT TO DO:
Pilot doesn't light	1. Pilot burner not getting gas.	<ol style="list-style-type: none"> 1. Check to see if tank valve is "ON" 2. Control off-on set to "pilot" 3. Red reset button depressed (it may take 30 to 60 seconds to bleed all air from line)
	2. Pilot orifice blocked.	<ol style="list-style-type: none"> 1. Remove flare nut and 1/4" line. See Fig.1 No. 14. 2. Pull line back & remove orifice. 3. Clean with compressed air, DO NOT use drill bit or wire as this may change the size of the orifice and cause an improper or unsafe flame.
	3. Control Knob not in "Pilot" position	<ol style="list-style-type: none"> 1. Check to see if control knob is set in "Pilot" position
Pilot will light but doesn't stay lit.	1. Are you using a Low Pressure Regulator?	<ol style="list-style-type: none"> 1. If a Low Pressure Regulator is not being used, install one. Operation of unit with out one could ruin the Robert Shaw Unitrol unit. (Blow out the bellows)
	2. Thermocouple not hot enough.	<ol style="list-style-type: none"> 1. Hold red reset button down longer. It should not take more than 30-40 seconds.
	3. Damaged thermocouple or just bad (Kinked, hole, frozen, etc)	<ol style="list-style-type: none"> 1. Replace with new one. 2. Tighten thermocouple nut finger tight plus 1/4 turn and NO MORE. Overtightening may damage thermocouple or magnet.
	4. Pilot flame in wrong position.	<ol style="list-style-type: none"> 1. Flame should Contact the upper 1/3 and including the tip of the thermocouple (3/8" to 1/2") Bend flame deflector hood as needed. Operates best when bent in "L".
	5. Pilot flame is wrong size.	<ol style="list-style-type: none"> 1. Adjust pilot adjustment screw. See Fig. 2b. If thermocouple has swelled, flame is too hot and thermocouple may be damaged. (Order a new one.)
	6. Weak magnet.	<ol style="list-style-type: none"> 1. Replace gas valve (Unitrol). NOTE: See test procedure No. 2.
	7. Red Button Melted or Deformed	<ol style="list-style-type: none"> 1. The knob will not push down into correct position. Replace Red Knob
Pilot lights but burner doesn't.	1. Control off-on set to "PILOT."	<ol style="list-style-type: none"> 1. Turn Control off-on to "ON."
	2. Temperature dial too low.	<ol style="list-style-type: none"> 1. Turn temperature dial to a higher number.
	3. Temperature sensing bulb too warm.	<ol style="list-style-type: none"> 1. Bulb must be less than 60 degrees to light Burner. If bulb is less than 40 degrees & burner still won't light, see next cause. Sensing bulb must be below water level in bulb guide.
	4. Temperature sensing bulb or line is damaged.	<ol style="list-style-type: none"> 1. Dents in temperature sensing bulb partially crushed due to water freezing in the bulb tube guide (see Fig. No. 2) or sharp bends in the line may cause the control to "think" the temperature is higher than it is. If the damage is major, a new gas valve (Unitrol) is required. Temperature sensing bulb not sold Separately.

Trouble Shooting

PROBLEM	POSSIBLE CAUSE	WHAT TO DO:
	5. Temperature dial calibration wrong.	1. See Fig No. 4 for recalibration procedures.
	6. Damaged bellows.	1. Temperature sensing bulb exposed to either high temperature or crushed due to water freezing in the bulb tube guide. (The bellows housing may exhibit a large gap to the main valve body) See Figure No 2. 2. May have to replace Robert Shaw UNITROL unit.
	7. Dirt in burner orifice.	1. Remove burner and orifice. 2. Clean with compressed air. DO NOT use drill bits or wire to clean. This may change the orifice size and cause im proper or unsafe burner operation.
Burner lights but doesn't shut off.	1. Temperature sensing bulb too cold.	1. Warm to 50 degrees and check.
	2. Temperature sensing bulb or line damaged causing a leak.	1. If temperature sensing bulb has lost some or all of Its fluid, the control will "think" the temperature is colder than it is. 2. Order a new gas valve (Unitrol). Temperature sensing bulb not sold separately.
	3. Temperature dial.	1. See Figure No. 4 for recalibration procedures.
	4. Expanded Bellows	1. Replace Robert Shaw UNITROL Unit
Melted valve knobs	1. Main burner orifice partly plugged	1. Remove burner and clean
	2. Low pressure or bad gas supply.	1. Correct gas supply.
	3. Burner assembly is not properly inserted into casing	1. Remove and re-insert burner assembly making sure that it is all the way to the bottom and tight against the boot. 2. Replace melted knobs
	4. Chimney could be partially plugged.	1. Remove burner assembly. Blow compressed air into top of chimney to remove debris.
Sensing Bulb froze down in tube	1. Frozen water in tube	1. Put vegetable oil in tube but keep close watch, vegetable oil will float on water.
<i>Continued On Next Page</i>		

Trouble Shooting

PROBLEM	POSSIBLE CAUSE	WHAT TO DO:
Burner assembly works fine outside of Casing, but goes out when in Casing.	1. Wind blowing out flame.	1. Always keep top cover closed. 2. Try to point the tip of the boot into the prevailing wind.
	2. The stack (chimney) passage plugged.	1. Clean out the passage (chimney).
	3 Lack of air flue convection.	1. Allow sufficient time for the pilot light heat to create a convection after installing burner assembly in casing before starting the main burner.
	4. Excessive water (condensation) build-up in Casing.	1. Empty water and operate at a slightly higher temperature dial setting. Runs best between #4 and #6.

Trouble Shooting

Figure No. 2: Gas Valve (Unitrol)

2a. Top View

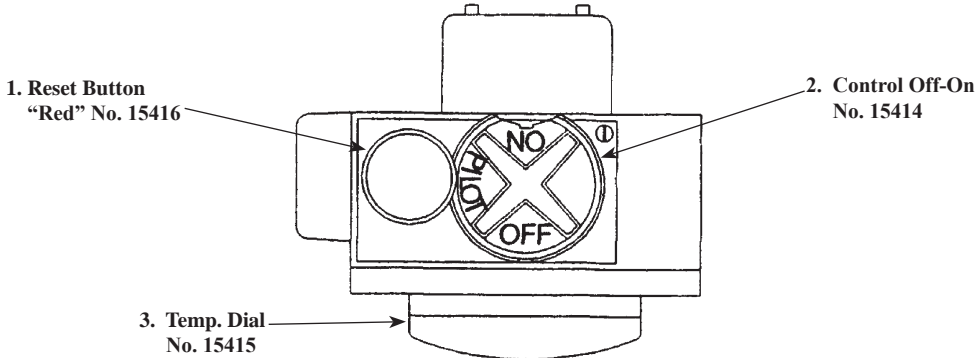

2b. Side View

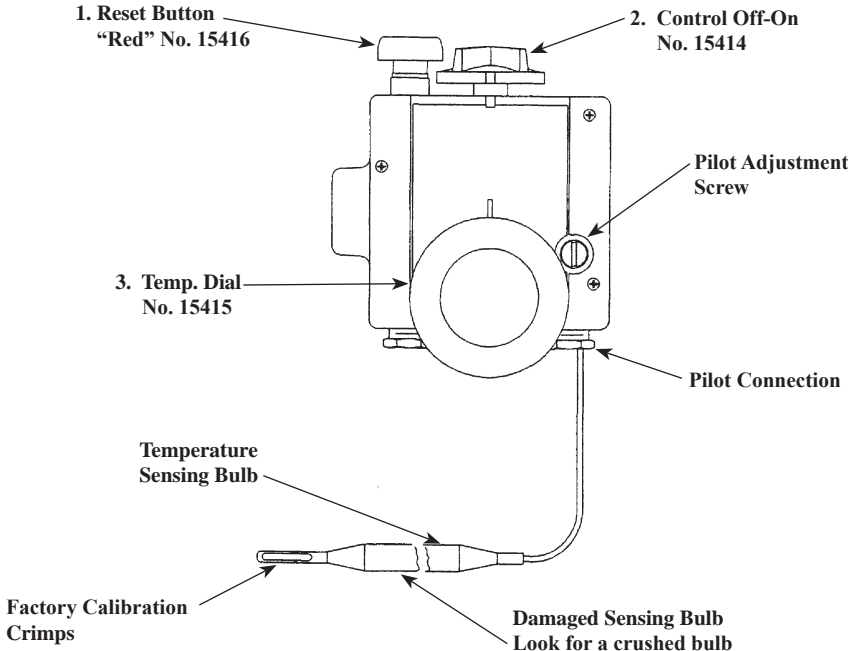

2c. End View

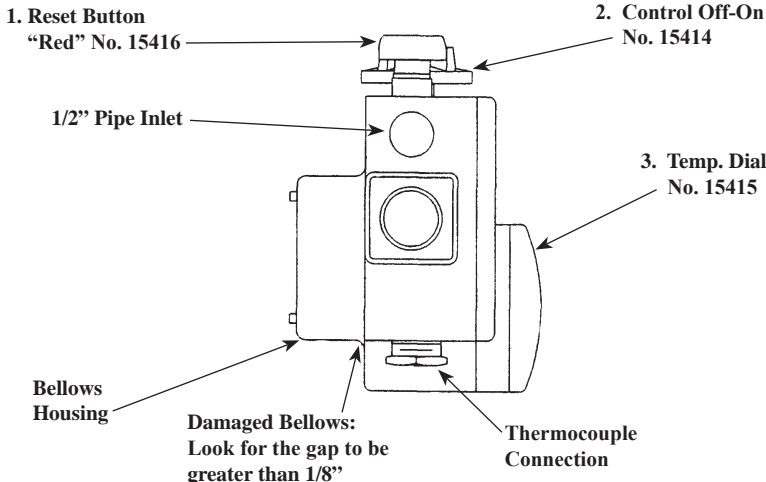

Trouble Shooting

Pilot Burner Adjustment (see Figure 2 and 3)

1. Adjust pilot adjustment screw (Figure 2b) to provide properly sized flame (Figure 3).
2. Improper flame size can result in pilot light not staying lit (Figure 3).

Figure 3. Troubleshooting Pilot Flame

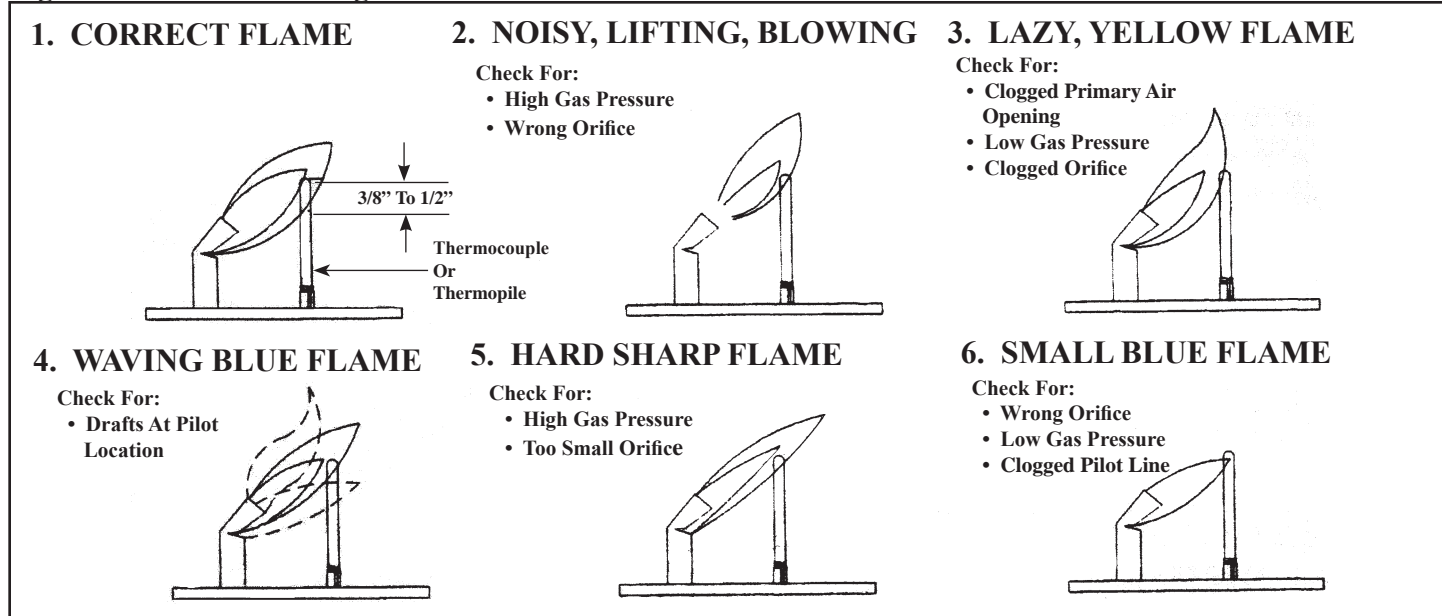

Test No. 1 To Test Thermocouple Using Millivolt Meter And Robertshaw Adapter #75036* (see fig. A)

Test No. 2 To Test Magnet Using Millivolt Meter And Robertshaw Adapter W75036 (see fig. A)

1. Unscrew thermocouple from control.
2. Screw Robertshaw adapter #75036 into control.
3. Screw thermocouple into adapter.
4. Connect millivolt meter leads to adapter and thermocouple as shown in fig. A.
5. Light pilot and allow it to heat tip of thermocouple for three minutes. If pilot will not stay lit, hold red reset button down during this test.
6. If meter reads below 13 millivolts, replace thermocouple. If meter reads 13 millivolts or more, the thermocouple is good.

Figure A.

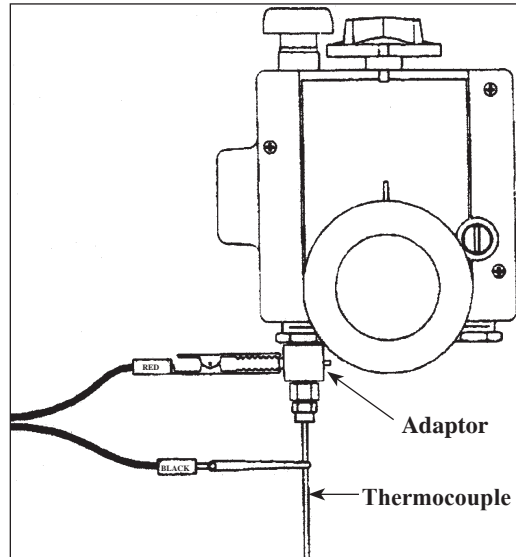

1. After testing thermocouple and replacing if necessary as described above, follow normal pilot lighting procedure with adapter and millivolt meter attached as shown in fig. A.
2. Allow pilot to burn for three minutes.
3. Note millivolt reading on meter and blow out pilot.
4. Magnet should continue to hold for a drop of five millivolts or more before it releases. A "snap" can be heard when magnet releases. If magnet does not hold for a drop of at least five millivolts, replace control. Magnet is good if it holds for a drop of five millivolts or more.

Trouble Shooting

Figure No. 4 Re-Calibration of the Robertshaw 110SS Gas Heating Control (see Figure No. 2 for details)

If the burner will light but will not shut off, the temperature sensing bulb probably has lost some of its fluid. A new gas valve (Unitrol) will be required.

If there has been MINOR damage to the temperature sensing bulb or line on your gas valve (Unitrol), the burner may not light. The temperature dial may be re-calibrated in this case. If the damage is major, it will not be possible to re-calibrate and a new gas valve (Unitrol) will be required. Temperature sensing bulb is not sold separately.

TO RE-CALIBRATE:

1. Remove the temperature dial.
2. Using needle-nose pliers, hold the pointer on the dial shaft.
3. Loosen the nut holding this pointer.
4. Move the pointer clockwise approximately 90 degrees (1/4 turn).
5. Re-tighten nut.
6. Replace temperature dial.
7. Turn temperature dial and note where valve “clicks” off. For correct calibration, the temperature sensing bulb should be 52 degrees when the dial is at #5 position.
8. If this calibration is not suitable, repeat steps 1 through 7.
9. There is a limit to how much the unit can be calibrated. If these steps do not correct the problem, a new gas valve (Unitrol) may be required.

Temperature sensing bulb not sold separately.